

# Model AMT

**Dewpoint Transmitter 4-20mA. Ranges available between -120°C to +20°C (-184°F to +68°F) dewpoint**

**Model AMT Dewpoint Transmitter** is a two wire 4-20mA loop powered transmitter, used for continuous measurement of moisture in dry process gases or dry compressed air, which will output a linear 4-20mA signal corresponding to the dewpoint temperature. The Model AMT transmitter can also be factory configured to output a 4-20mA linear signal for any other moisture unit e.g. ppm(v), ppm(w), g/m<sup>3</sup>, lb/MMSCF etc.

**Fast Response - Stable - Reliable - Accurate - Easy to Install.**

The Ultra High Capacitance sensing element is long lasting and offers excellent sensitivity, repeatability and response speed. Each unit is supplied with a Certificate of Calibration, traceable to International Humidity Standards, validating accuracy better than ±2°C dewpoint.

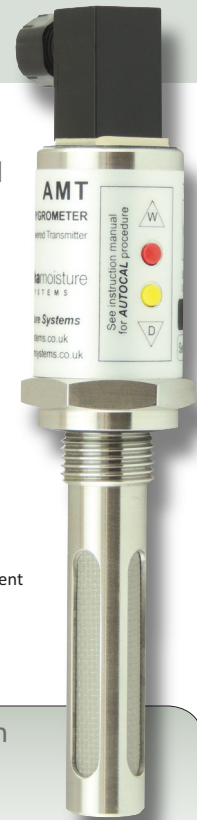

**CE**  
 Measuring instrument conforms with BS EN 61326-1

## FEATURES

- 2 Wire Loop Powered Dewpoint Transmitter
- Overall Range: -120°C to +20°C Dewpoint
- Accuracy better than ± 2°C Dewpoint
- INTEGRATED AUTOMATIC CALIBRATION
- Can be configured for linear 4-20mA signal in: °C & °F Dewpoint, ppm(v), ppb(v), g/m<sup>3</sup>, lb/MMSCF
- Temperature Compensation
- Failure Diagnostics
- Long Term Stability
- Fast Response Time
- IP66 / NEMA4X Protection

The transmitter also incorporates an Automatic Calibration (AUTOCAL) feature, which allows the user to carry out a field calibration / span check. The **AUTOCAL feature** is operated by two small button switches built within the transmitter enclosure. To avoid tamper, the switches are locked in normal use and can only be activated by following a specific routine from the manual.

The integral RISC microprocessor circuitry of the **Model AMT** transmitter allows high resolution with advanced self diagnostics for fault conditions. It also enables periodic re-calibration of the moisture sensor, storing calibration data within the fully self contained unit. Loop powered by a 7V to 28V dc source, the **Model AMT** transmitter will provide a linear 4-20mA signal over the chosen range.

The mechanics of the **Model AMT** transmitter have been designed to cope with extreme environmental conditions. The rugged stainless steel construction offers protection to IP66 (NEMA4X), with the transmitter electrical connections made via a secure industrial connector.

**Model AMT** transmitter can withstand 35,000 kPa (350bar) maximum pressure and by employing a low resistance cable, the transmitter can be located at significant distances, in excess of 1000 metres, from the control room.

Designed with the operator in mind for reliable and accurate measurements, the **Model AMT** transmitter is extremely easy to install and operate, requiring little or no maintenance.

The **Model AMT** transmitter is supplied with a Certificate of Calibration, an instruction manual and 2m connecting cable.

**Note:** The **Model AMT** is not suitable for Ammonia (NH<sub>3</sub>), Chlorine (Cl) and Hydrogen Chloride (HCl). SF<sub>6</sub> can be monitored with no effect to the sensor element. Sulphur Dioxide (SO<sub>2</sub>) can be monitored if the moisture content is low, less than 100ppm(v).

## Specifications

### MODEL AMT Dewpoint Transmitter

#### 4-20mA Loop Powered Transmitter

**TRANSMITTER TYPE:** 2 Wire, 4-20mA Loop Powered Transmitter

**OUTPUT SIGNAL:** 4 to 20mA Linear

**OPERATING VOLTAGE:** 7V - 28V dc. Reverse polarity protected.

**MAXIMUM SERIES RESISTANCE:** = {40 x (Supply Voltage - 7)} ohms

**SENSING ELEMENT:** Ultra High Capacitance - Aluminium Oxide Type

**RANGES:** See How to Order Below

**AUTOCAL:** Field calibration / Span check facility. Activated and operated via two button switches on the Transmitter body. Locked in normal operating mode to avoid tamper.

**FACTORY CALIBRATION:** Supplied with Certificate of Calibration traceable to NPL / NIST

**ACCURACY:** Better than  $\pm 2^{\circ}\text{C}$  dewpoint (NPL / NIST traceable for range  $-90^{\circ}\text{C}$  to  $+20^{\circ}\text{C}$ )

**TEMPERATURE COEFFICIENT:** Temperature compensated for operating range.

**REPEATABILITY:** Better than  $\pm 0.3^{\circ}\text{C}$  dewpoint

**OPERATING TEMPERATURE:**  $-20^{\circ}\text{C}$  to  $+60^{\circ}\text{C}$

**STORAGE TEMPERATURE:**  $-20^{\circ}\text{C}$  to  $+70^{\circ}\text{C}$

**OPERATING PRESSURE:** From 1kPa (0.01 barA) to Maximum 35,000kPa ( 350 barA)

**OPERATING HUMIDITY (External):** Maximum - 95% RH Non-condensing

**SAMPLE FLOW RATE:** Flow independent but ideally 2 to 5 litres per minute. Max: 25 litres/min.

**CABLE TERMINATIONS:** IP66 (NEMA4X) rated, size C, DIN EN 175301 connector at the Transmitter and other end terminated with bootlace ferrules.

**CABLE:** Supplied with 2m standard cable. Nominal diameter 3.4mm, 92ohms/km at  $20^{\circ}\text{C}$

**ELECTROMAGNETIC COMPATIBILITY (EMC):**

Complies to BS EN 61326-1

**WARM UP TIME:** 10 seconds

**FAULT CONDITIONS:**

**Open Circuit :** Output drives to 20.50mA

**Short Circuit :** Output drives to 20.75mA

**ISOLATION:** Sensing Element connected to the 4-20mA loop but isolated from Transmitter body.

**TRANSMITTER ENCLOSURE:** 316 Stainless steel body with size C, DIN EN 175301 connector.

**SENSOR PROTECTION:** 316 Stainless steel mesh - 50 micron

**PROBE MATERIAL (WETTED PARTS):** 316 Stainless Steel

**WEATHERPROOF CLASSIFICATION:** IP66 / NEMA4X when Connector mated to Transmitter.

**MECHANICAL CONNECTION:** 3/4" UNF (16tpi) with integral Viton "O" ring seal.

**MECHANICAL WARRANTY:** 24 months in case of faulty workmanship and defective parts.

**CALIBRATION WARRANTY:** 12 months.

**ACCESSORIES INCLUDED:** Standard 2 meter connecting cable.

### How to Order - Step 1 of 4

Select a Range Below

Model AMT- [X]

<b>SD(F):</b>	-100°C to +20°C (-148°F to +68°F) dewpoint	} resolution = 0.1°C / °F
<b>LD(F):</b>	-120°C to +20°C (-184°F to +68°F) dewpoint	
<b>HD(F):</b>	-65°C to +20°C (-85°F to +68°F) dewpoint	
<b>SILVER</b>	-110°C to -20°C (-166°F to -4°F) dewpoint	
<b>RED</b>	-80°C to -20°C (-112°F to -4°F) dewpoint	
<b>GREY</b>	-80°C to 0°C (-112°F to +32°F) dewpoint	
<b>BLUE</b>	-80°C to +20°C (-112°F to +68°F) dewpoint	
<b>PURPLE</b>	-100°C to 0°C (-148°F to +32°F) dewpoint	
<b>SP:</b>	1 to 1000 ppm(v) - - - - - resolution = 1ppm	
<b>MP:</b>	0.1 to 100.0 ppm(v) - - - resolution = 0.1ppm	
<b>LP:</b>	0.01 to 10.00 ppm(v) - resolution = 0.01ppm	
<b>PB:</b>	1 to 1000 ppb(v)- - - - - resolution = 1ppb	
<b>HG:</b>	0.01 to 10.00 g/m3 - - resolution = 0.01g/m3	
<b>LG:</b>	0.001 to 1.000 g/m3-resolution = 0.001g/m3	
<b>LB:</b>	0.1 to 100 lb/MMSCF	

Order Example:- Dewpoint Transmitter Model DS1200-AMT-SDC(F) =  $-100^{\circ}\text{C}$  to  $+20^{\circ}\text{C}$  dp  
Model DS1200-AMT COMES COMPLETE WITH A STANDARD 2 METRE CONNECTING CABLE.



### How to Order - Step 2 of 4

Select A Longer Cable Below

CAB069-AMT + [XX]

Your AMT Transmitter comes complete with 2 metres of connecting cable as standard.

To order a longer length in metres, add number after this part number.

Example: CAB069-AMT-10 for 10 metres

Non-Standard off the shelf cables available in 3, 4, 5, 10, 12, 15, 25m lengths. For longer lengths please call.

AMT Standard Cable 2 Meters



Part No. CAB069-AMT

### How to Order - Step 3 of 4

Order a Display Below

Model DS1200



- Perfect for continuous online measurements
- Fast Response
- 22V - 253V AC or DC operation
- Single channel in-line hygrometer
- Panel protection to IP65 (NEMA4X)
- 2 independent alarms
- 2 independent alarms

For more details please see data sheet DS1200.

### How to Order - Step 4 of 4

Select a Transmitter Holder Comes complete with mounting plate.

2 grades available: 303 or 316 Stainless Steel

ADSH-AMT 303 + [X] [X]  
ADSH-AMT 316 + [X] [X]

X = Choose INLET Pipe Fitting

0 = None 1/8" NPT Port  
4 = 1/4" - Pipe OD  
8 = 1/8" - Pipe OD  
6 = 6mm - Pipe OD

X = Choose OUTLET Pipe Fitting

0 = None 1/8" NPT Port  
4 = 1/4" - Pipe OD  
8 = 1/8" - Pipe OD  
6 = 6mm - Pipe OD

Order Example:- For Transmitter Holder 303 grade with 2 x 1/4 fittings Order ADSH-AMT 303 - 4 - 4

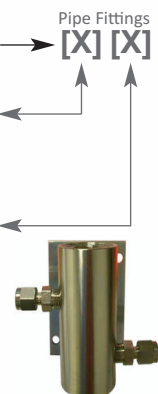

## Dimensions

### Model AMT Dewpoint Transmitter

4-20mA Loop Powered Transmitter

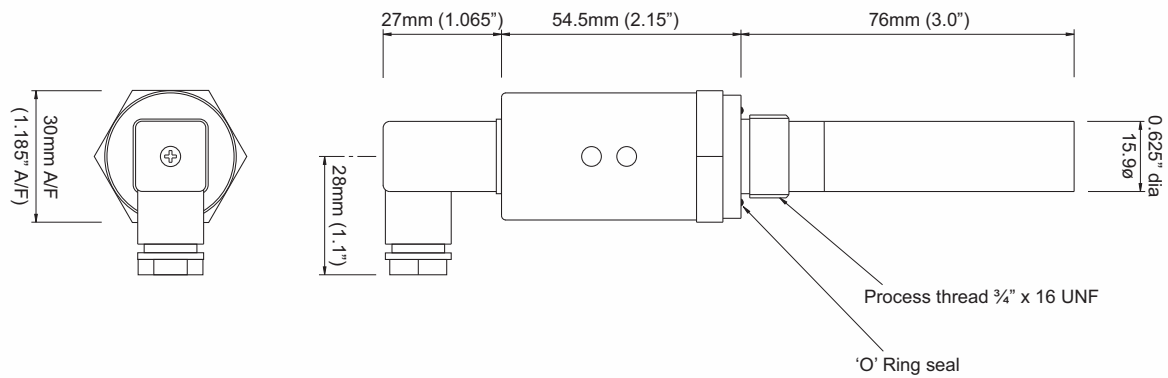

### Model ADSH-AMT Transmitter Holder

Flow Through Sample Cell

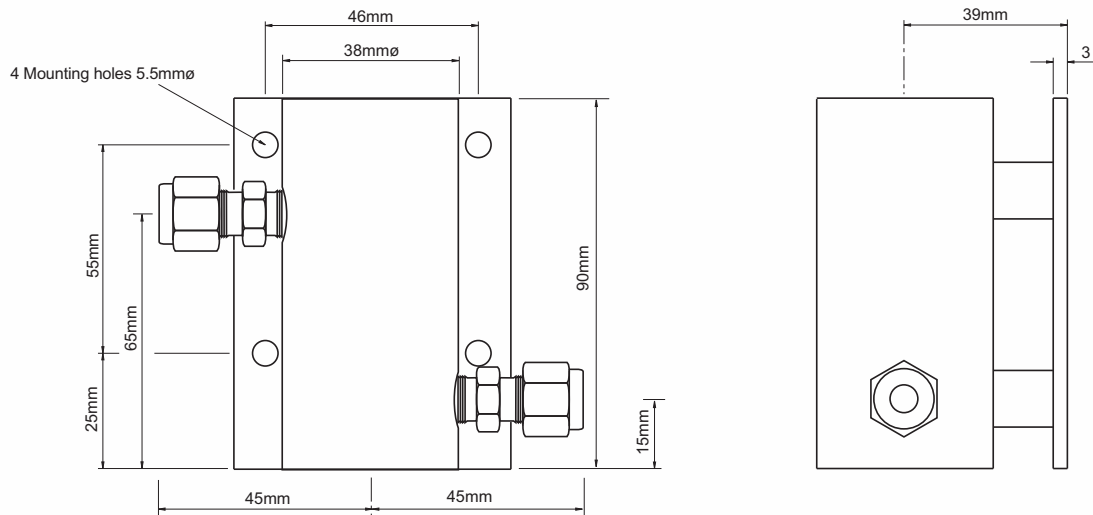

Note: The Assembly is shown with 1/4" OD tube fittings. The dimensions across the tube fittings will vary for all other size fittings.

### Model DS1200 Display

Stable, Accurate and Reliable Alarmed Monitor

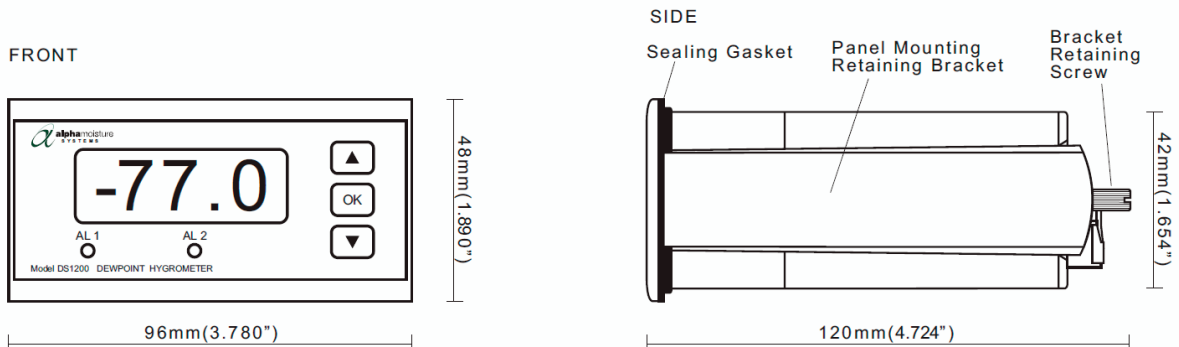

2146 Model AMT pd130618-ISS 5

Alpha Moisture Systems Limited.  
Registered Office: Alpha House,  
96 City Road, Bradford, BD8 8ES. UK.



CERTIFICATE No. FM35600  
BS EN ISO 9001:2015

Registered in England and Wales No. 3902302  
VAT Registration No. GB607207563  
WEEE Producer Registration No. WEEE/EA0067TX

© Alpha Moisture Systems Ltd.

Tel +44 (0) 1274 733100

Fax +44 (0) 1274 733200

Email [info@amsystems.co.uk](mailto:info@amsystems.co.uk)

Website [www.amsystems.co.uk](http://www.amsystems.co.uk)

Product specification may be subject to change.